



E-Toilet Services Limited

Beggars Roost, Sedge Green, Nazeing, Essex CM19 5JR

TEL: +44 (0)1992 44 22 97

FAX: +44(0)1992 899 441

Email: info@ets.co.uk

Web: www.etoiletsales.co.uk

A PRIVATE SPACE IN A PUBLIC PLACE

ETS Vacuum Module mod.1000/1300 mm Transversal Technical Data Sheet

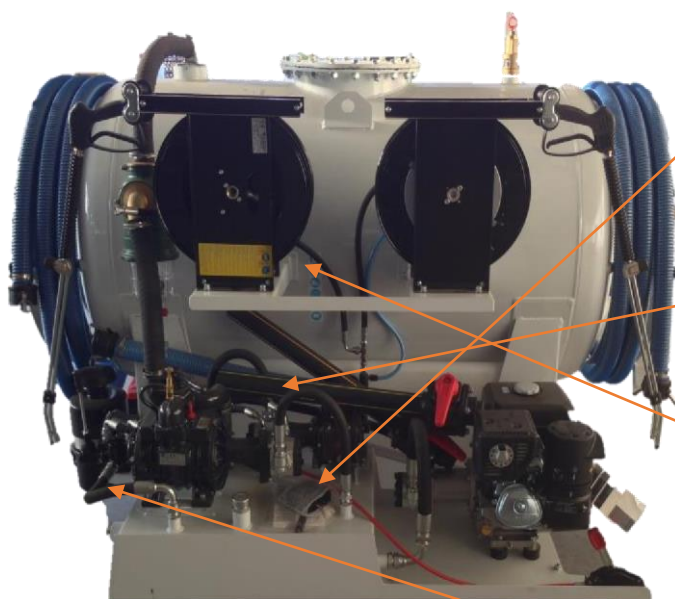

Water pump 150 bar/200 bar according to the model- 15 l water/min.



Hydraulic engine performance 1980 l/min. (air)/2500/min. according to the model



Sanitary concentrate tank capacity 5 l



Noise reducer and waste oil filter

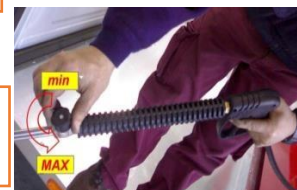

Double barrel spray gun allows the regulation of the washing pressure

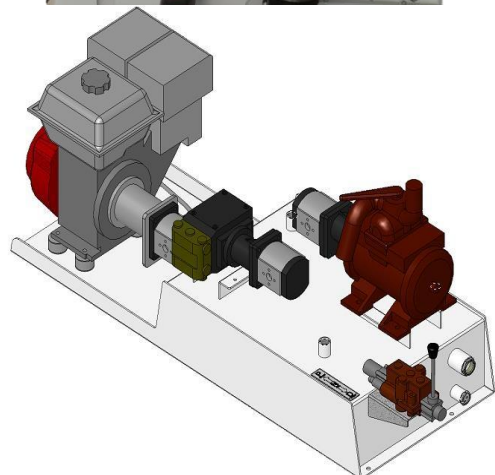

Mechanical and Technical Characteristics:

The high-pressure water pump and the decompressor are powered by a hydraulic motor.

The petrol fuelled (13.5 CV) combustion engine, flanged to a hydraulic pump, permits the generation of the power needed for functioning of the equipment.

The hydraulic oil tank holds approximately 45 litres.

The system is mechanically independent: connected to the cistern, the system can be made to function on stand-alone configuration.

Vacuum module maximum pressure:1.5 bar.

Environmental operating conditions: Operating temperature from 0°C to 40°C.



STANDARD EQUIPMENT

Manhole allows the tank inspection and internal cleaning

The water tank is installed under the wastewater tank to improve stability and weight balance on the truck floor. It is provided with 3 plastic level check eye holes to monitor presence of water.



The transversal type saves room on the truck wheelbase, so it allows the transportation of four Armal toilets.

Hoses	Mod. 1000 mm	Mod. 1300 mm
Waste suction hoses length (No.2)	9,50 m	12,50 m
Washing hoses length with automatic hose reel (No.2)	10 m	10 m



Auxiliary Engine	Honda mod. GX390
Cylinder capacity	389 cm ³
Power max.	8.2 KW @ 3600rpm 11.0HP @ 3600 rpm
Torque max.	25.1 Nm @ 2500 rpm 2.56 kgm @ 2500 rpm
Consumption	3.7 l/h @ 3600 rpm
Fuel	Petrol
Ignition	Pull start with self-winding (electric optional)
Battery	12 V – not available
Electrical system	12 V cc

Further Characteristics of the Waste Suction System	
Max. vacuum decompressor	-0.89
Lubrication oil – decompressor:	ISO VG 100
Hoses:	Press. Max. 10 bar

Further Characteristics of the Washing Hydraulic System	
Hoses	Press. Max. 1120 bar
Combined operating	No

Dimensions	Mod. 1000 mm	Mod. 1300 mm
Tanks capacity	1100 l waste – 460 l water	2000 l waste – 640 l water
Length	1540 mm	2000 mm
Width	2105 mm	2105 mm
Height	1500 mm	1900 mm
Weight	670 kg	850 kg

Optional Extras

The machine may be fitted with systems and special installations according to the Customer's specific needs:

- a heating system for the water to be used to wash the inside and outside of the toilets, by means of a gas oil burning boiler. This unit heats the water coming from the tank before it is possibly mixed with detergent and pressurized to be sprayed through the guns.
- an electric-hydraulic radio control system for remote operating of the equipment using a radio transmitter/receiver.
- an odour abatement system composed of an electronic control unit operating an electric pump which vaporizes and emits a scented liquid into the drainage hoses of the decompressor to eliminate or reduce the production of unpleasant odours during the operating phases especially during suction of organic waste.



Vacuum modules are in compliance with CE Markings and supplied with CE conformity declaration



Easy Toilet Services

For further information, please contact

E-Toilet Services Limited

Unit 7 Millbrook Business Park, Hoe Lane, Nazeing, Essex EN9 2RJ

TEL: +44 (0)1992 899 453

FAX: +44(0)1992 899 441

Email: toilets@ets.co.uk

Web: www.etoiletsales.co.uk

A PRIVATE SPACE IN A PUBLIC PLACE